

Spark Detection and Extinguishment Systems Offer Safety for Your Production

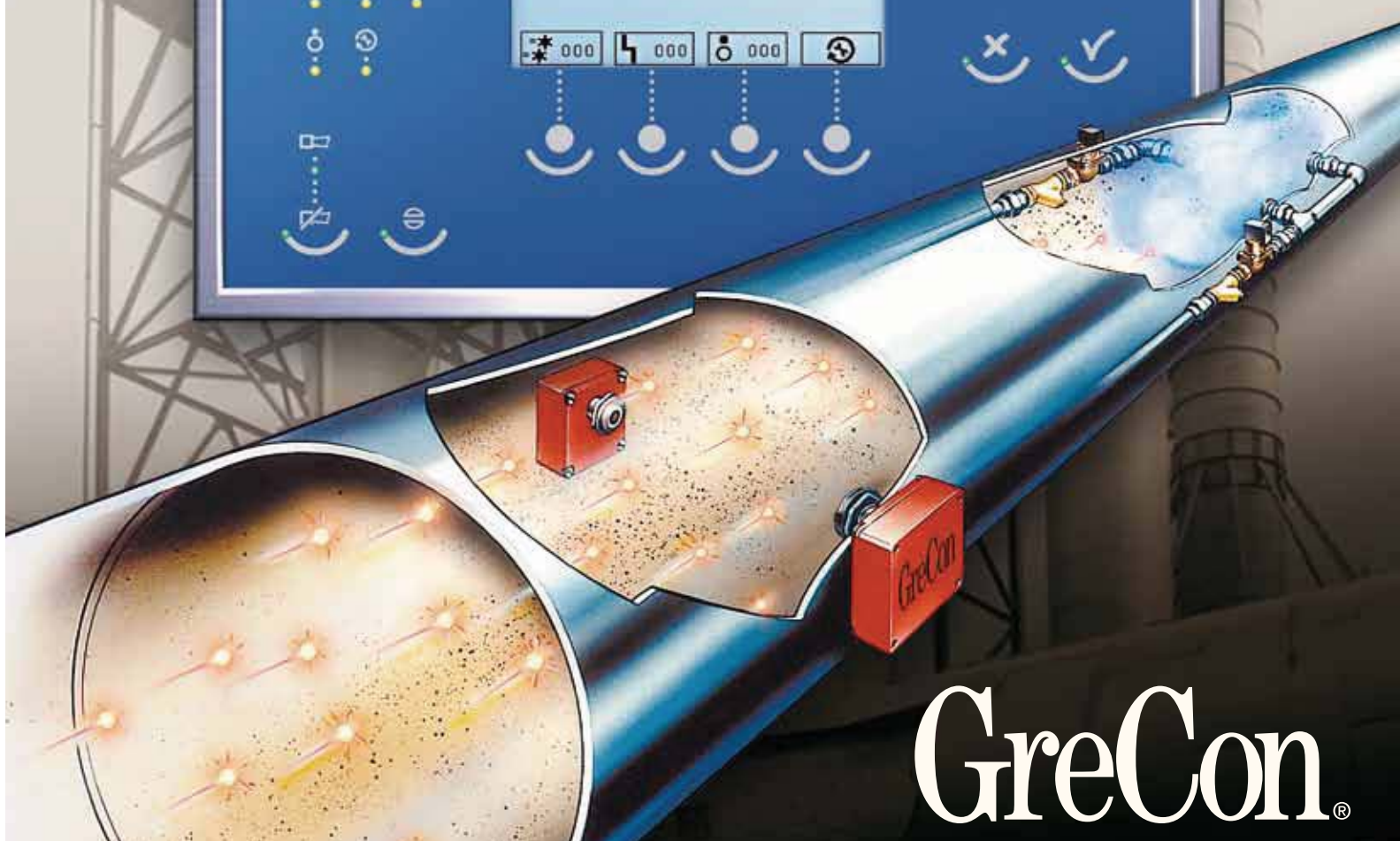

AIR Industries

13 SWANSON RD
NEW BOSTON, NH 03070 603-487-1117



GreCon®

Spark Detection/Extinguishment Systems Safety for Your Production

Spark detection and extinguishment systems detect and automatically extinguish sparks. The risk of dust fires and explosions can thus be reduced.

Dust fires and explosions often occur in filters, silos and dryers. They endanger human lives, cause severe property damage and interrupt production operations. The reason can be sparks or burning embers caused when working with or drying combustible material and reaching plant areas at risk through the pneumatic and mechanical conveying systems.

Within the framework of its special technology and its distinct design, the GreCon system was developed to detect and extinguish these ignition sources in pneumatic exhaust systems before they reach filters and silos and cause a fire or explosion in these areas!



Protection of Dust Filters and Silos

Spark sensors are flush-mounted on the walls of the exhaust ducts to detect the infrared radiation emitted by sparks in the transport air stream.

Immediately upon spark detection, a water mist spray is released into the duct and the sparks are extinguished. The extinguishing device consists of a special high-speed solenoid valve with one or more spray nozzles. These are flush-mounted to the duct wall about 4 to 6 meters (12 to 18 feet) downstream of the sensors, depending on the conveying velocity.

Extinguishment is accomplished with water at high flow pressure. Special extinguishing nozzles spray a water mist, which covers the entire cross section of the duct. With a properly planned installation, the ignition sources enter the water mist and are effectively extinguished. The valve closes after a preset and adjustable time frame, normally 5 seconds.

The GreCon system effectively detects and extinguishes ignition sources without machinery shut-down or interruption of the production process. The amount of water released is sufficient to extinguish the sparks, but generally does not adversely affect the filter media.



Protection of Dryers

Sparks and burning embers can occur any time combustible materials are dried. Sources of spark danger can be uncontrolled machinery shut-down, overdried material within the dryer or overheated material build-up in the ducting. Overheated glowing particles leave the dryer, come in contact with oxygen in the air, and may cause a fire or explosion. All plant areas connected by the pneumatic conveyor system and even the dryer itself can be affected. Because temperatures in this area exceed the operating temperature of standard sensors, sensors with fibre optic cables are utilised.

GreCon sensors can detect sparks in pneumatic transport ducts of dryers or in discharge chutes and mechanical conveyors.

Upon detection of sparks, pre-programmed counter-measures are automatically triggered; i.e., release of extinguishing spray, closing or aborting pneumatic pipes, or, in extremely critical cases, shut-down of and deluging the dryer or filters.



Protection of Milling Equipment

With high speed milling equipment, heavy showers of sparks may be generated when metal or stones enter the mill or when mechanical parts are damaged. GreCon sensors detect these showers of sparks and activate the extinguishing devices.

The GreCon system counts each spark as it is detected. The system can be pre-programmed to extinguish individual sparks without interrupting production and additionally shut down machinery upon counting a preset number or shower of sparks. This feature protects machinery from further damage due to mechanical failure or foreign material in the mill.

Spark Detection Preferably in Dark Areas



Thermo detector

Combustion gases detector

Preferable location for a GreCon Spark Detection and Extinguishment System is within a pneumatic conveying duct or other areas where ambient light is not present. This ensures the high sensitivity of the sensors so that the detection of ignition sources can be optimised even in dense material flow. The optics of the sensors are normally kept clean by the air and material flow which makes the system easier to maintain.

Spark Detection in High Temperature Areas

Sensors with fiber optic cables are used where processing or drying temperatures exceed 65° C (149° F). Three separate stainless steel covered glass fiber cables transmit the infrared radiation to the sensor with each cable ending on a separate photo optic diode. Solid glass adapters are added to the cable end for extremely high temperatures. Detection reliability is achieved by using three detection elements per sensor. The fiber optic cables are available in different lengths for different duct diameters.

Additional fire detection

Thermo detectors not only react when exceeding the set temperature threshold but activates an alarm upon fire-typical temperature rises.

Burning embers deeply hidden in the material release gases. These gases can be detected - in a silo or storage bin - by a combustion gases detector. This provides preventive fire detection before the gases ignite.



Sensor with fiber optic cables

Spark Detection under Daylight Conditions

GreCon can detect sparks on conveyor belts, production lines, or at transfer points between conveyor systems. A special sensor is used where ambient light is present.

Interference-Free Installation

Sensors and spray nozzles are flush-mounted in the duct walls with special mounting adapters can be screwed or welded so that they do not obstruct the material flow.



Mounted
spark sensor



Mounted
extinguishing nozzle



① Extinguishing nozzle* · ② Spark sensor* · ③ Daylight spark sensor* · ④ Fiber optic spark sensor*
* with mounting adapter

Spark Extinguishment

Water Extinguishment

A fine water mist spray emerges from the extinguishing nozzles and is used for extinguishment. They are made of high-quality stainless steel, which increases the resistance to wear. After extinguishment, the shutter cone of the nozzle automatically seals it and keeps it free of contamination.



Water Pressure Booster Pump

If the available water flow pressure is inadequate, a pressure increasing unit is installed to create the required water pressure. If the water flow rate to the pressure increasing pump is too low, or, if the unit is connected to a drinking water supply, a storage tank must also be installed.

Diversion of Material Flow

Different traps, valves and gates are available to interrupt or divert hazardous material flow. They can counteract the risk of transmission of ignition sources to endangered plant areas.

Anti-Freeze Protection

Heat tape and insulating material can be used to protect water pipes and extinguishing devices from freezing in areas exposed to frost. We offer special insulating bags for the extinguishing devices.





Extinguishing device



Air purge adapters

Additional Measures against Heavy Dirt Accumulation

If dirt accumulation or other build-up on the sensor optics is expected, special air purge adapters increase the detection reliability. Cleaning intervals are thus extended.



GreCon Control Console

The control console is the core of a spark extinguishing system. It records, analyzes and stores all events. In case of alarms or trouble messages, suitable counter-measures can be automatically initiated. Robust, dust-proof housings make the use in industrial conditions possible. The operation and connection elements are ergonomically arranged and allow quick and precise system operation. Thanks to maintenance-free batteries, uninterrupted protection is assured in case of a power failure.

Ease of Operation

Personnel can easily operate the system. Comfortable user guidance is accomplished via a full-graphic LC display. Up to four operation languages are pre-installed via the firmware and can be changed at any time.

Self-Monitoring

An automatic system testing function checks sensors and extinguishing valves at regular intervals. This substantially reduces manual checks by operating personnel.



Operating panel

Alarm Safety Concept

A variable safety concept allows for adequate response to individual alarm events. Example: the extinguishment of a single spark, the automatic diversion of hazardous material flow, or the shutdown of machinery during abnormal spark activity.

Repeated spark detection within short intervals can give a clue to a faulty production process. To be notified of this condition or to avoid long extinguishments, an additional alarm can be activated or the individual production process can be shut down automatically.

Recording of Events

The GreCon console stores up to 2,500 events, which can be shown in a full-graphic LC display at any time. All recorded events can be transferred to a PC for detailed analysis and evaluation under Windows to determine potentially hazardous areas or malfunctioning processes or equipment.



Central Visualisation

Events recorded by several consoles, which are installed in different areas of the plant, can be stored on an OPC server. Using a standard visualisation system, an overview of the current condition is ensured at any time. If a suitable visualisation system is not available on site, GreCon can offer project-specific visualisation.

Evaluation of Events and Defence against Danger

The GreCon console displays and records information from each individual occurrence of sparks; i.e., time of occurrence, exact number of sparks, duration of the event, and location of the spark occurrence. Chronological recording of alarms is accomplished for each monitoring zone exactly to the millisecond. Alarms in connected zones can be evaluated in chronological order locating the cause, propagation and effect.

Protection against Damage Caused by Water

The GreCon system automatically monitors the extinguishing assemblies and immediately triggers an alarm in case of no water flow or water system leakage, considerably reducing the risk of water damage.

Modular Design

The control console consists of modular components so that there is no size limit. The capacity of the console can be adapted to the required application.

Expansions are possible at any time by adding extension cabinets.

A further advantage is the possibility to install several consoles locally and operate them via a remote operation panel centrally, in a control station, for example.





①·②·③ Control consoles with different capacities

Maintenance

High-quality abrasion resistant materials are used for all components that come in contact with the material flow. This greatly reduces the wear to sensor optics and extinguishing nozzles.

Rapid connections and a modular design make the replacement of components easy. The stand-by batteries of the console are maintenance-free.



Experimental station - permanent development



After-Sales Service and Maintenance

The GreCon after-sales service is available at any time. Complete training and instruction of the operating personnel is part of this service. During the maintenance of the system, which is usually carried out once or twice a year, technical improvements or software updates can be implemented. The GreCon after-sales service can give online support via a remote control function.

State-of-the-Art Technology

GreCon Spark Detection and Extinguishment Systems are fully warranted and are approved by Factory Mutual (FM) and the German Insurance Association (VdS). These institutions require stringent manufacturing standards and technical reliability. These standards also apply to planning and after-sales service.

GreCon has their own experimental station to test new applications. GreCon spark detection and extinguishment components can be generally installed in Ex zones 20, 21 and 22 in consideration of the valid Ex regulations.



Extraction system with spark detectors



Mounted spark detector



Anti-freeze protection of extinguishing devices with insulating bags

Application Recommendations

A GreCon Spark Detection and Extinguishment System can easily be installed in existing production plants. However, it is advantageous to take the installation of a spark detection and extinguishment system into account when planning a new plant.

The mounting of sensors and nozzles is very easy. Standard non-shielded wiring may be used for the electrical installation. The installation of the extinguishing system is made with standard water pipes.

References

GreCon protects more than 100 different industries with over 100.000 applications of the GreCon Spark Detection and Extinguishment System worldwide. Reliable after-sales service is available 24 hours a day to assist you and ensure your plant's safety.

Selected Examples

Particleboard Industry

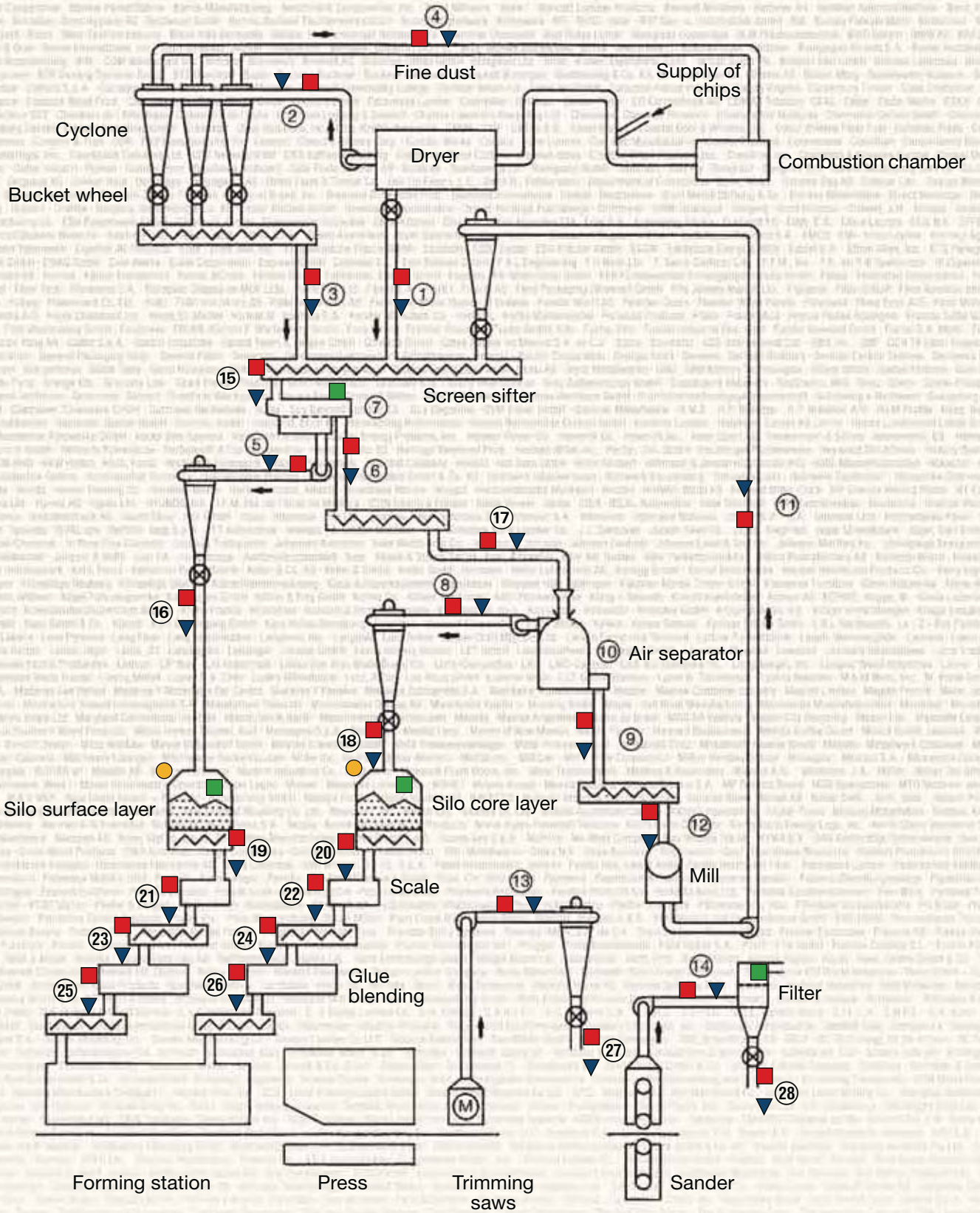

Furniture Industry

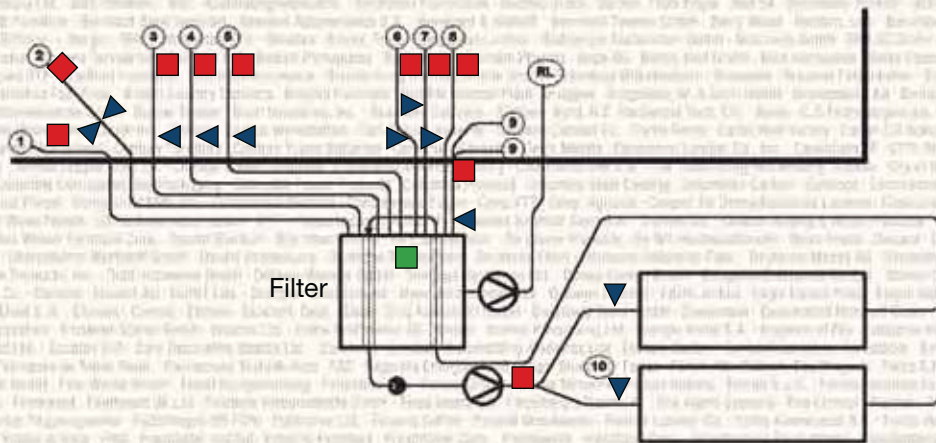

Mills

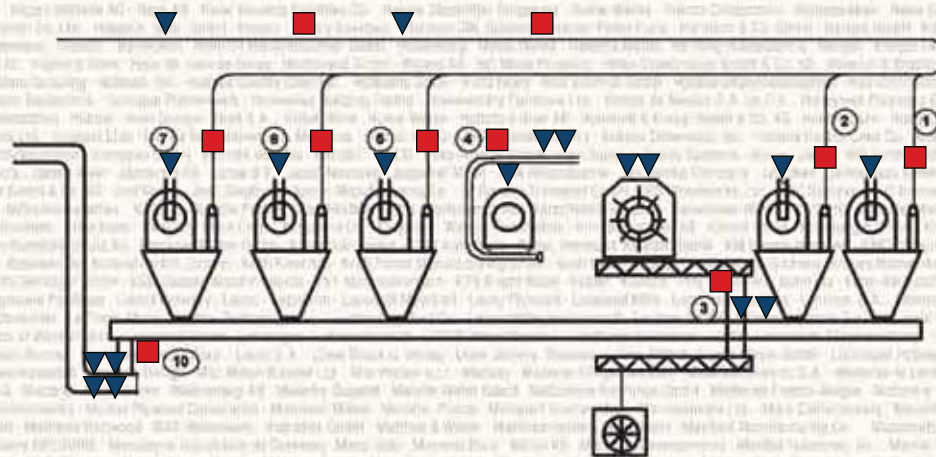

Metal Recycling

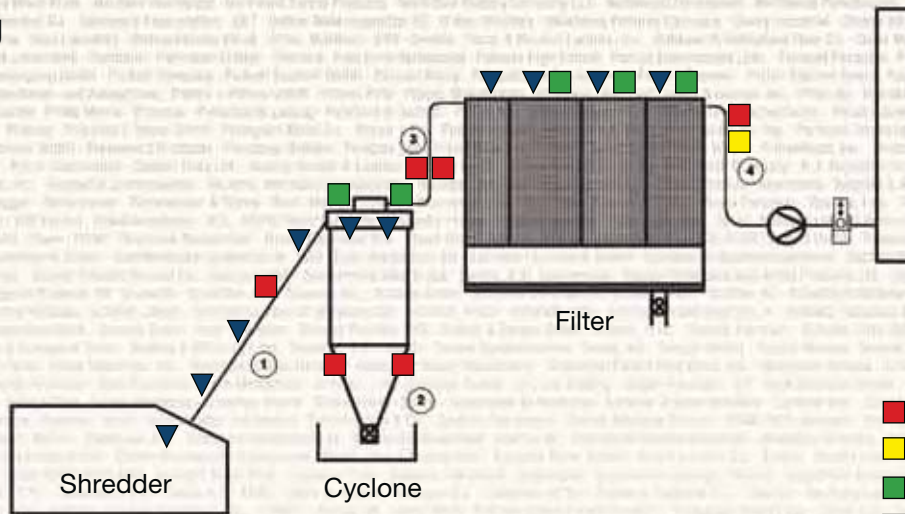

- Spark Detector
- Smoke Detector
- Thermo Detector
- ▼ Extinguishing Device
- Combustion gases detector

We have a suitable solution for your application, too!



OUR HEADQUARTERS AT ALFELD - BUILT BY WALTER GROPIUS IN 1911



GreCon

GreCon, Inc.
15875 S.W. 74th AVE.
TIGARD, OR 97224

TEL: (503) 641-7731
FAX: (503) 641-7508
EMAIL: sales@grecon-us.com
WEB: www.grecon-us.com

