



# AIR Industries

13 SWANSON RD  
NEW BOSTON, NH 03070 603-487-1117

# Nederman

IMPROVING YOUR WORKSPACE



**Safe and sound solutions for  
Fire and Emergency Stations**



## Exhaust fumes seriously affect firefighters' health

Diesel exhaust, found in every fire station, is produced when an engine burns diesel fuel. It is a complex mixture of thousands of gases and particles (soot) containing several toxic air contaminants. These include many known or suspected carcinogenic substances (benzene, arsenic and formaldehyde). It also contains other harmful pollutants, including nitrogen oxides. In the long term, repeated exposure is as dangerous as being subject to cigarette smoke. The exhaust spreads into the areas where firemen eat, sleep and reside. It penetrates the clothes.

No wonder cancer rates among firemen are exceptionally high.

### The only effective method: exhaust extraction directly from the tail pipe

Nederman's exhaust extraction systems are designed specifically for emergency vehicles. The exhaust fumes are removed right from the tail pipe, which is the only effective way of doing it. More than 100,000 Nederman systems installed in emergency stations all over the world is a proof for that!



### The wrong way

*General ventilation and re-circulations systems are not enough to extract volatile diesel fume!*



### The right way

*Extraction directly from the exhaust pipe is the only effective way to eliminate the dangers of exhaust fumes.*



## No one is better than Nederman at making the station sound and safe

We can offer you an exhaust extraction system which fulfils the specific needs of your premises and suits your economy. No matter the size of your station, sizes/types of vehicles or frequency of operations.

We have the market's widest range of products and systems, as well as extensive experience and knowledge in how to build the optimal solution.

### Nederman exhaust extraction systems

- **Track systems:** cost effective back-in systems for small to medium large stations.
- **Rail systems:** high capacity drive-through systems for medium and large stations.
- **Vertical Stack systems:** for back-in or combined back-in/drive-through.

### Nederman nozzle/hose attachments

Nederman Track Systems and Rail Systems are available with pneumatic or magnetic attachment.



***Pneumatically attached nozzle.**  
Perfect for stations where vehicle types vary.*



***Electromagnetic attachment.**  
The system offers extraction efficiency second to none.*

# Track Systems



## Cost effective back-in systems

<p><b>MagnaTrack HS</b> Electromagnetic attachment</p> 	<p><b>MagnaTrack ST</b> Electromagnetic attachment</p> 	<p><b>Pneumatic Track System PTS</b> Pneumatic attachment</p> 
<b>Application</b>		
For high-frequency/ high-speed applications	For stations with fewer runs	For interchangeability between vehicles
<b>Capacity vehicle/system</b>		
1	1	1
<b>Exhaust pipes</b>		
Low level or high level	Low level	Low level

*All products are not available on all markets*

# Rail Systems

# Stack Systems

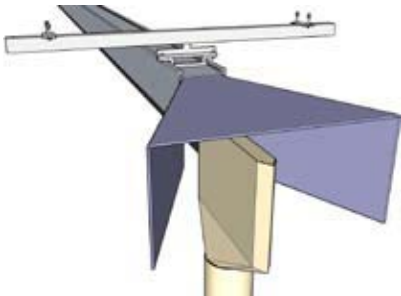
High capacity back-in or drive-through systems		Back-in or drive-through	
<p><b>MagnaRail</b> Electromagnetic attachment</p> 	<p><b>Pneumatic Rail System PRS</b> Pneumatic attachment</p> 	<p><b>MagnaStack</b></p> 	<p><b>Vertical Stack</b></p> 
		<b>MagnaStack</b>	<b>Vertical Stack</b>
Application			
The ultimate solution offering outstanding performance	High capacity and interchangeability between vehicles	Back-in. Up to normal sized engines	Drive-through and back-in. For large volume engines
Capacity vehicle/system			
Up to 4	Up to 4	1	1
Exhaust pipes			
Low level or high level	Low level	Vertical stacks	Vertical stacks

## Electromagnetic systems



### Matchless extraction, exit speed and capacity

- An electromagnet attaches the extraction unit to the vehicle
- Enables quick exits
- Superior exhaust removal capacity
- Outstanding for stations with high callout frequencies
- Comes with Nederman MagnaRail, MagnaTrack ST and MagnaTrack HS

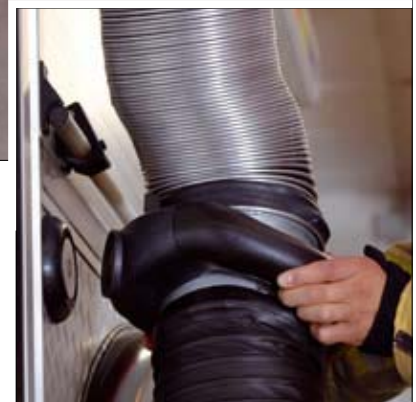

*When activated, the electromagnet on the hose attaches to an anchor plate on the vehicle.*

### Outstanding extraction efficiency

The design of the nozzle enables complete extraction of the exhaust fumes – and, at the same time, removal of residual emissions from the tail pipe system. The 100 %-PLUS extraction capability makes MagnaSystem second to none.

### High heat resistance

Another feature, unique to these systems, is that the nozzle also draws in ambient air, cooling the entire extraction system. This is an important advantage when handling the increasingly higher exhaust temperatures generated by modern engines.



**Fastest exit speed on the market**

*The magnetic attachment mechanism releases the nozzle immediately on exit. The release distance to the door is adjustable.*



**The most ergonomical way to attach the nozzle**

*The operator avoids bending down and breathing residual exhaust fumes while attaching the nozzle to the exhaust pipe. The hose is conveniently guided into position using the grip and is held in place by the electromagnet.*



**Smooth release eliminates swinging hoses**

*The magnetic mechanism releases smoothly, preventing tension build-up. There is no slingshot effect, pendular motion is reduced, and the risk of damage to nearby staff or vehicles is eliminated.*



**Hose without loops**

*As the system has no hoses coiled in loops or trailing behind, space is saved between vehicles and the risk of hose swing is greatly reduced – a great advantage in small bays. Furthermore the vertical hoses cannot become entangled, important when the alarm sounds.*



**Hoses designed for optimal extraction**

*Our 6 1/4" hose permits a high airflow with low pressure drop, allowing the fan to operate with optimal efficiency. Thus, the fan does not have to be oversized, which saves energy and keep noise at a low level.*

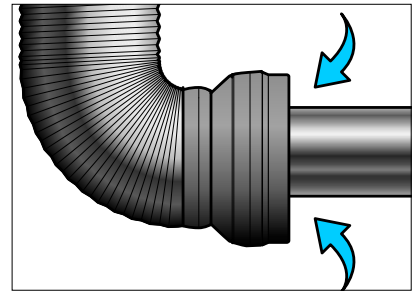

**100% PLUS extraction and heat resistance**

*The nozzle extracts 100% of the exhaust fumes and simultaneously draws in ambient air for cooling. This makes MagnaSystem perfect for modern engines generating very high exhaust temperatures. The nozzle also extracts residual emissions that may leak from the tail pipe system.*

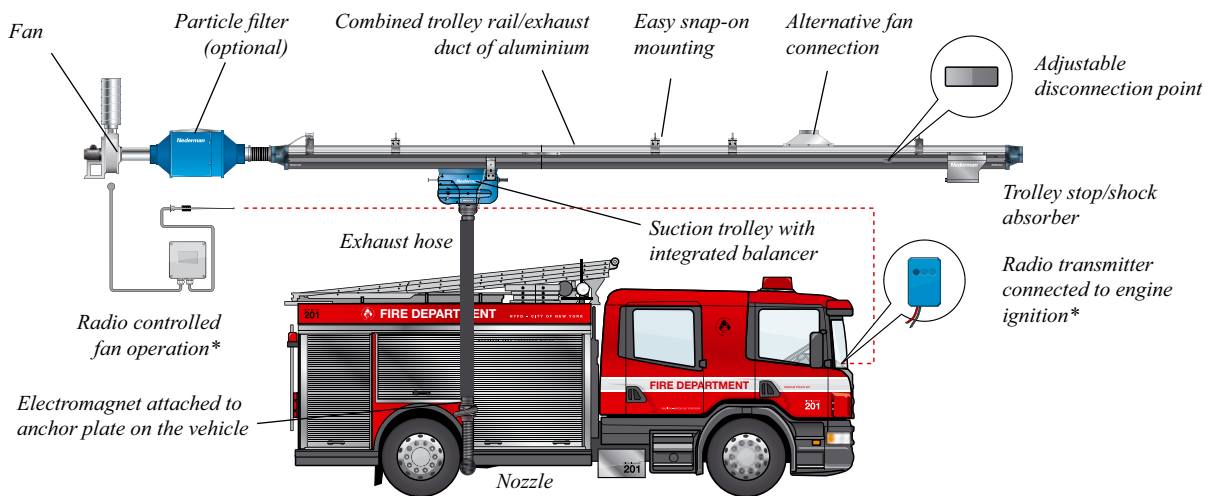

**The principle of electromagnetic systems**

*\*) Optional – A system can be supplied with different fan activation options such as radio control, pressure sensor, or manual switch.*

# Pneumatic Systems

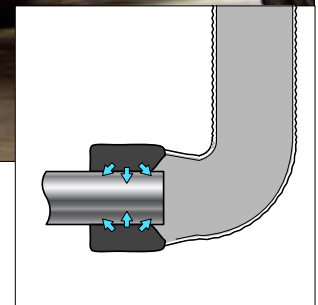

## New improved pneumatic systems

- The nozzle is expanded with compressed air for tight fixing and sealing around the tail pipe
- Perfect for stations where vehicles types vary
- Two sizes of nozzles for different tail pipes
- Quick coupler for easy change of nozzles
- Comes with Nederman Pneumatic Rail System PRS and Pneumatic Track System PTS

*When activated, the air chambers expand and attach the nozzle firmly on to the tail pipe.*

### Quick and safe exits

On leaving the station, when the vehicle reaches a preset point, the air pressure in the nozzle is released and disconnected from the tail pipe. A valve automatically releases the pressure instantaneously. The valve can also be operated using a switch on the grip.

### Unique, new safety disconnection

As an extra protection, in case of faulty operations, a safety coupler ensures that the hose is disconnected from its mount.

### Fan activation options

The system can be supplied with different fan activation options such as pressure sensors, radio control units or manual switches.



**Air vent for quick and safe exits**

*The air pressure in the nozzle is released quicker than in other systems. The activation point for hose release can be set as close to the exit doors as required.*



**Safety coupling**

*As extra protection, in case of faulty operation, there is a safety coupling to ensure that the hose is not pulled off its mount.*



**Interchangeable nozzles**

*PTS is supplied with a choice of two easily interchangeable nozzles to suit different tail pipe dimensions. The nozzles have a heat resistant inlay of Nomex.*



**Grip for ergonomic handling**

*A robust grip for two-handed use positioned at a convenient working height provides ergonomic handling when attaching the nozzle to the tail pipe.*



**Exhaust hose with integrated compressed air hose**

*4" exhaust hose for easy operation. The compressed air hose connected to the nozzle attachment is well protected inside the exhaust hose.*



**Fan activation options**

*The system can be supplied with different fan activation options such as a pressure sensor, radio control unit or manual switch.*

**Pneumatic Track System – PTS**

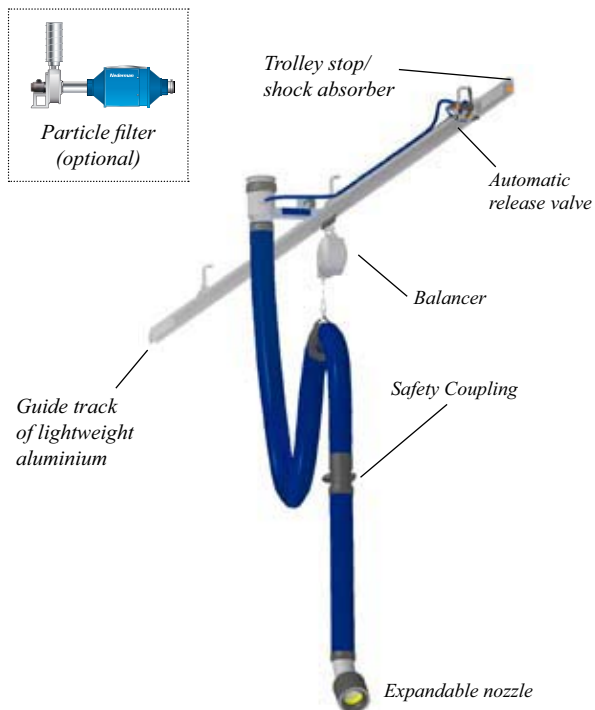

**Pneumatic Rail System – PRS**

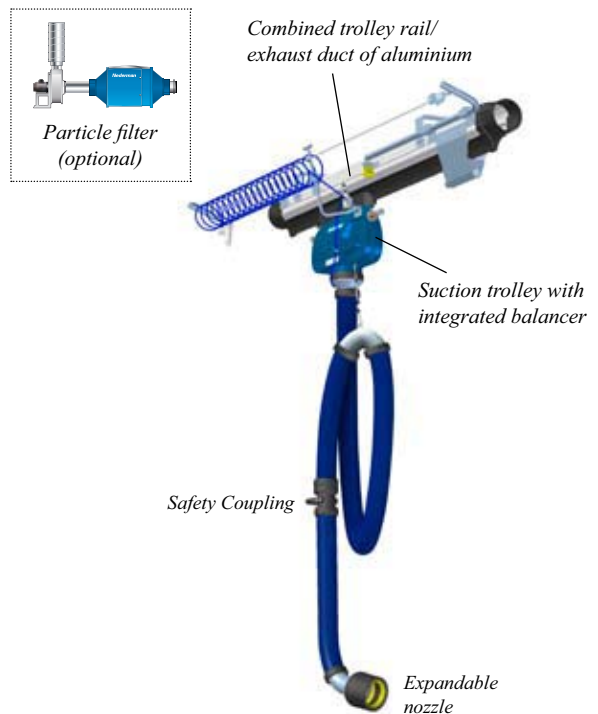

# Total solutions

No one better than we can create the most optimal solution for sound, safe and ergonomic Fire and Emergency Stations. From a single source of supply you get the most comprehensive solutions fulfilling the latest standards and leading technologies.

We help you all the way – from planning, design and commissioning to maintenance and service support. More than 60 years of experience and well over 100,000 installations in emergency stations make us second to none.



## ■ PARKING AREA EMERGENCY VEHICLES

with Exhaust extraction  
and particle filtration

- 1. Pneumatic Rail System PRS
- 2. Particle filter and fan system

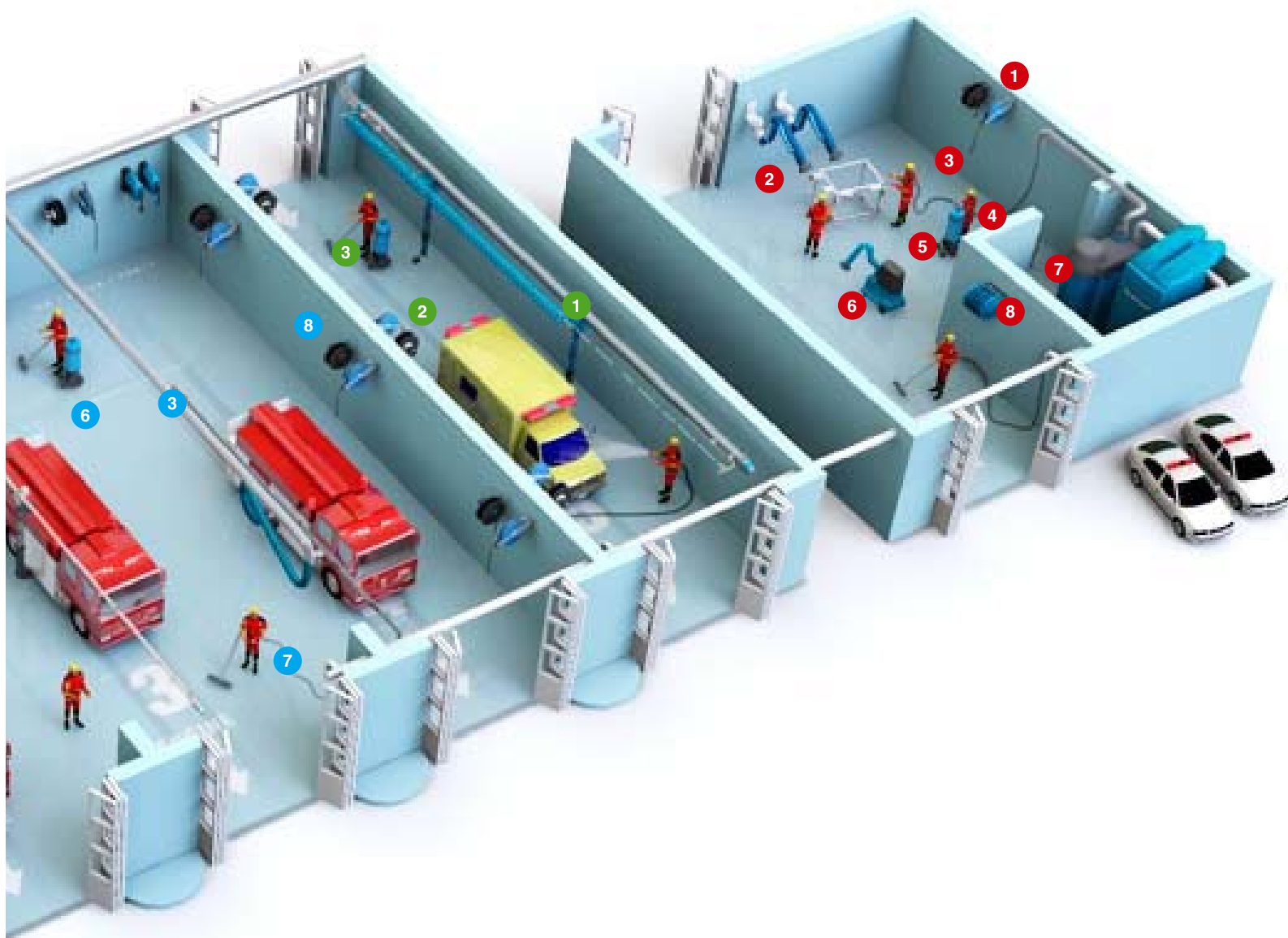

**PARKING AREA  
FIRE VEHICLES**  
with Exhaust extraction  
and particle filtration

- 1. Magna Rail
- 2. MagnaTrack HS
- 3. Pneumatic Track System PTS
- 4. Vertical Stack
- 5. Particle filter and fan system
- 6. Mobile vacuum cleaning unit
- 7. General cleaning - central system
- 8. Cable and hose reels for electricity and air supply

**WASH HALL**

- 1. Pneumatic Rail System PRS
- 2. Reels for water
- 3. Mobile vacuum cleaning unit

**MAINTENANCE  
AND OVERHAUL**

- 1. Reels for air, water, gases, electric power etc
- 2. Arms for welding fume extraction
- 3. Welding torch with integrated fume extraction
- 4. On-tool extraction: grinding, sanding etc
- 5. Mobile blaster unit
- 6. Mobile extraction/filtering unit
- 7. Central cleaning and filtration system
- 8. Exhaust reels

# Do not take unnecessary risks!



## Get a free consultation!

e-mail or send us some photos and a drawing of your station and we will, as a first step, provide you with good advice on how to make your station sound and safe with our systems.

## [www.fire.nederman.com](http://www.fire.nederman.com)

You'll find all the information you need about our products, systems and references on our website.

You'll also find facts and reports about health effects and risks of diesel exhaust fumes exposure, and helpful tips.

# Nederman

[www.nederman.com](http://www.nederman.com)

**Nederman Sales companies in:** Australia, Austria, Belgium, Brazil, Canada, China, Czech Rep. Denmark, France, Germany, Hungary, India, Ireland, Northern Ireland, Norway, Poland, Portugal, Romania, Russia, Slovak Republic, Spain, Sweden, Turkey, United Kingdom, USA  
**Nederman Agents in:** Bulgaria, Cyprus, Egypt, Estonia, Finland, Greece, Holland, Hongkong, Iceland, Iran, Ireland, Italy, Japan, Korea, Latvia, Lithuania, Malaysia, New Zealand, Philippines, Saudi Arabia, Serbia, Singapore, Slovenia, South Africa, Switzerland, Taiwan R.O.C, Thailand, Turkey, United Arab Emirates